

# UNIVERSITY SMALL SATELLITE PROGRAM – ANUSAT

**K. Thyagarajan, J.P. Gupta, Dr. P.S. Goel, Prof. K. Jayaraman\***

ISRO Satellite Centre

Bangalore - India

## ABSTRACT

Indian Space Research Organisation (ISRO) over the last 3 decades has steadily progressed towards establishment of space system for communication, earth observation and disaster warning for national development. Also, the launchers for placing both earth observation and communication satellites have been developed. While these efforts are being sustained on a continuous basis, ISRO initiated Small Satellite Program few years ago for demonstration of new technologies that can be adopted to operational mission as well as Small Satellite Earth Observation program to complement the existing earth observation mission. Also realizing the importance of steady flow of engineers and scientists in Space Technology, ISRO has been pursuing to promote development of micro-satellite at Indian universities that will provide hands - on experience to the university students in Space Technology and also developing new technologies for the future. Anna University at Chennai, India has taken up the first micro-satellite program within the university environment. The micro-satellite development will be carried out at Aerospace Research Centre in Anna University with review and funding support from ISRO. The project will be implemented through involvement of students, researchers and faculty staff. The satellite is a simple spinning satellite carrying Store & Forward payload being the first mission and weighs less than 50 kg. The Project has commenced in January 2002. The Preliminary Design Review of the satellite has been completed in December 2002. The micro-satellite is scheduled for launch in 2005 as an auxiliary payload in ISRO's launcher PSLV (Polar Satellite Launch Vehicle).

## 1.0 INTRODUCTION:

Micro-satellite development at University environment provides hands-on experience of building a satellite from design through launch and orbit operations for students in a cost effective way. Since multi-disciplinary effort required for satellite program are normally seen in the university, this kind of projects coupled with team building would provide valuable contribution to aerospace field, not only by training scientists and engineers for the future but also as a tool for development of new technologies through the thinking found in university environment for future system.

Anna University in Chennai, India is already active in teaching and research related to the aerospace disciplines. The micro-satellite development is to encourage the involvement of the Anna University faculty, researchers and students in Space technologies to work as a team. To gain hands-on experience a micro-satellite development project called ANUSAT is taken as a first step in the area of space technology. The major areas of development include structure, thermal management, control and guidance, power

---

\* Anna University, Chennai

system, command and data handling, communication, satellite integration and test. The expected outcome of the project would be:

- To establish a center of excellence in the development and usage of micro-satellites.
- To complement the development efforts of satellite application requirements by providing a micro-satellite platform for technology development
- To train scientists and engineers for future in space technology
- To initiate research activities towards development of micro-satellite.

## 2.0 PROGRAM OVERVIEW

ISRO has initiated development of micro-satellites at Indian universities to train students in Space Technology as well as development of new technology for the future. Anna University in Chennai is the first university that has taken up micro-satellite development at university environment.

Being the first mission of this kind ISRO provided to faculty and students of the university, training program on Satellite Technology and development with special emphasis on micro-satellite development. This was followed by setting task team at the university to prepare the report for implementing the project from the university.

Though several payload options were considered, Store and Forward payload was selected as it is easy to be realized from the university and it will also help to link other universities. Besides currently micro-satellite (HAMSAT) for HAM operators is being readied at ISRO. Thus this Store and Forward payload would support HAM operator's requirement as well. There are other secondary payloads for technology validation.

Being the first mission the satellite itself is made as simple as possible, so that the entire satellite and its elements can be built from the university and the end to end aspect of satellite building covering various elements can be well understood. Thus a simple spinning satellite using passive magnetic stabilization technique weighing less than 50 kg was selected.

The Project was approved by ISRO in January 2002. The Project at the university is being reviewed periodically by ISRO scientists for effective and timely implementation. Besides a management council jointly chaired by Vice-Chancellor, Anna University and Director, ISRO Satellite Centre is overseeing the efforts to ensure timely completion of the project meeting the mission objectives.

The preliminary Design Review of the project has been completed in December 2002. The launch is scheduled in the year 2005 as a auxiliary payload in ISRO's launcher PSLV. The required financial support for the project is provided by ISRO. The details of the micro-satellite ANUSAT currently under development at Anna University is outlined here.

## 3.0 ANUSAT :

The Micro-satellite being developed at Anna University, Chennai is a spinning cuboid structure of 600mm x 600mm x 600mm dimensions (Figure 1). The configuration of the micro-satellite is as in Figure 2. In addition on top deck it has projecting antenna elements of 500mm height. The satellite is made of Aluminium Honey comb structural

panels/decks and CFRP based solar panels. The satellite has silicon solar cells on four belly based panels to generate electrical power for the microsatellite. To meet the peak power requirements and the power needs during eclipse a Lithium-Ion chemical battery has been incorporated. The power distribution is through a battery clamped unregulated power bus feeding to DC/DC convertors. These DC/DC convertors in turn through appropriate switches supply regulated / conditioned power to different electrical systems of the micro-satellite. The micro-satellite is spin stabilized using a pair of magnetic torquers as actuators and utilizing 3 axis magnetometer and a twin slit sun sensor as sensing elements. The satellite uses passive Thermal control with appropriate surface treatments controlling its thermal properties. For temperature monitoring it uses thermistors. The satellite uses VHF Telemetry and Telecommand links for house-keeping data monitoring and commanding.

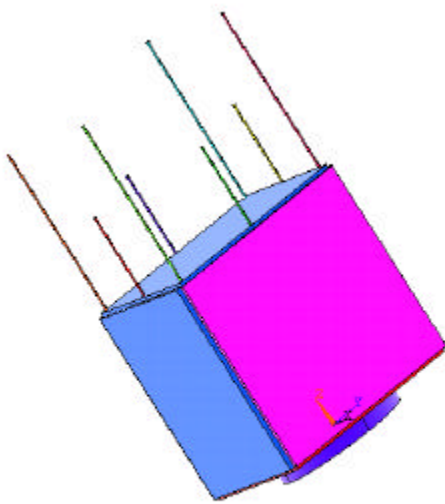

Figure 1: ANUSAT

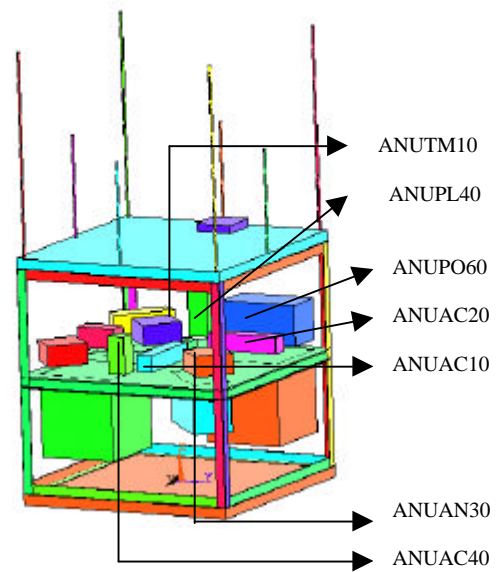

Figure 2: ANUSAT Configuration

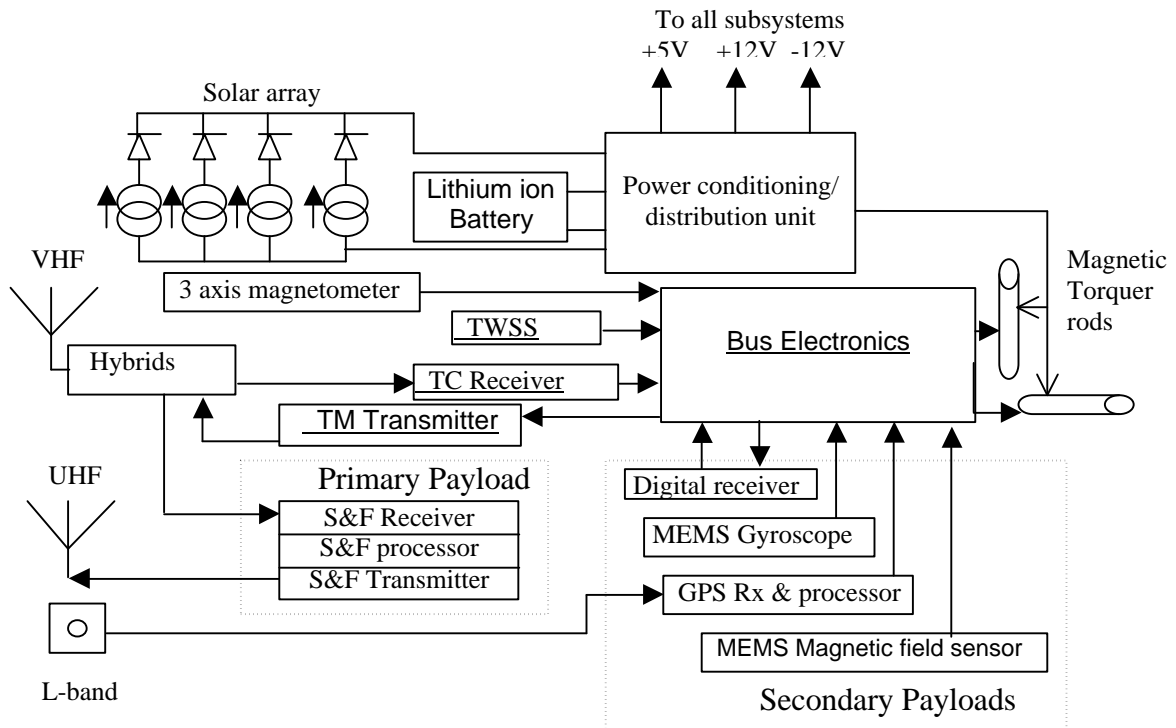

Figure 3 Block Diagram of University Micro-satellite ‘ANUSAT’

All the electronics is housed in a single Bus Electronics package. This Bus electronics is a processor based system with FPGA's to complement the functionalities. All command, telemetry, Attitude control system (ACS) electronics, sensor signal processing and actuator functions are performed by this bus electronic package. Spin rate control as well as spin axis control is performed autonomously by the satellite Bus Electronics resident in ACS system. The electrical schematic of the micro-satellite is as in Figure 3. Table-1 provides the specification of the satellite bus.

The satellite carries aboard a store and forward payload operating in Amature (digital) mode with VHF uplink and UHF down link operating in amature frequency bands. It provides digital communication facilities between a number of universities/colleges and amature satellite radio operators. The Microsatellite also carries aboard secondary payloads like MEMs Gyroscope, MEMs Magnetic field sensor and FPGA based GPS Receiver and Processor. All digital FSK Receiver and Turbo coder for data transmission as a technological payload is also being developed for technology validation.

Table – 1

Micro satellite Main Frame Specifications

1. Size	:	600mm x 600mm x 600mm cuboid
2. Mass	:	< 50 Kgs
3. Solar Array	:	Body mounted Silicon solar cells generating 33 Watts of Average power
4. Battery	:	Lithium-Ion, (4 x 4) 16 cell battery ; 6 AH capacity
5. Bus Voltage	:	13V to 16V
6. Telecommand	:	VHF (PCM/FSK/AM); 100 bits/sec, 149.2 MHz.
7. Telemetry	:	VHF( PCM/FSK/AM); 256 bits/sec., 137.4 MHz,
8. Stablization	:	Spin stablized with spin axis orientation towards orbit normal
9. Spin rate	:	4± 0.5 r.p.m. (automatic SRC)
10. Spin Axis Orientation	:	±3 <sup>0</sup> (Autonomous SAOC)
11. Sun Sensor	:	±75 degree range with 0.5 degree resolution for sun aspect angle
12. Magnetometer	:	± 45,000 gamma with 500 gamma resolution
13. Torquers	:	4.5 Am <sup>2</sup> each (Two Nos.)

4.0 CONCLUSION

Micro-satellite development at universities is an important tool to provide Space Technology research environment and develop Space Scientists and Engineers for future. Over 25 students and 15 faculty staff are involved in the program at the university. The students and faculty have participated right from concept evolution of this project. ISRO scientists are providing required support through reviews and training. ISRO facilities will be utilized for testing the satellite.

This project is also expected to provide new development like miniaturized communication system and turbo coding required for future mission . The project is being implemented in true spirit of micro-satellite development concept.

5.0 ACKNOWLEDGEMENT

The authors would like to thank Chairman, ISRO for supporting micro-satellite development at universities and Vice-Chancellor, Anna University for nurturing the same. The authors greatly appreciate and acknowledge the efforts of Anna University faculty and students for carrying out the micro-satellite development efforts and Director, ISRO Satellite Centre and ISRO scientists for reviewing the program periodically.